



FCM100  
NON CONTACT VALVE

**POLY DISPENSING SYSTEMS**  
S Y S T E M E S   D E   D O S A G E   I N D U S T R I E L

## Non Contact Valve FCM100

### Advantages

- Simple to install
- Fluid chamber separate from control
- Part in contact with the stainless steel fluid
- Process control amplified thanks to the possibility of detecting the droplet ejected with conventional sensors
- High resistance to high pressure
- Removal of the product in points or cords, at a distance from the support.
- Distance: 1 to 100 mm from the support.
- Exceptional advantages in terms of dosing speed
- Minimum accuracy of  $\pm 2\%$
- Potential rate: greater than 600 cycles / minute
- No residual drip



### FCM100 Non-Contact Micro Dispensing Valve

The FCM100 is ideal for any low viscosity underfill, encapsulant, conformal coating, and micro dot or bead dispensing project.

The FCM100 “propels” precise shots of fluid onto a substrate resulting in accurate patterns at a high robot speed as no in process z-axis adjustments are required. The FCM100 is compatible with all PVA automated platforms.

The FCM100 has many integrated features including:

- Interchangeable 22, 25, 27, 28, 30, 32, and 33 gauge tip designs for various dispensing profiles
- Micrometer flow adjustment with lock ring
- inMOTION™ dispensing with no z-axis motion needed
- Highly repeatable dot size results in superior pattern definition
- Dot and continuous line dispensing profile capability
- Divorced valve design prevents material contamination of the air body

## Characteristics

Size	152 mm x 19 mm x 19 mm
Weight	340g
Minimum Shot Size	0.83 $\mu$ l
Minimum Line Width	0.25 mm (0.010«)
Minimum Orifice Inside Diameter	0.08 mm (0.003«)
Viscosity Range	1 cps – 20,000 cps
Operating Air Pressure	60 – 100 psi
Operating Fluid Pressure	1-100 psi
Wetted Components	Stainless steel, Teflon® , Kalrez®

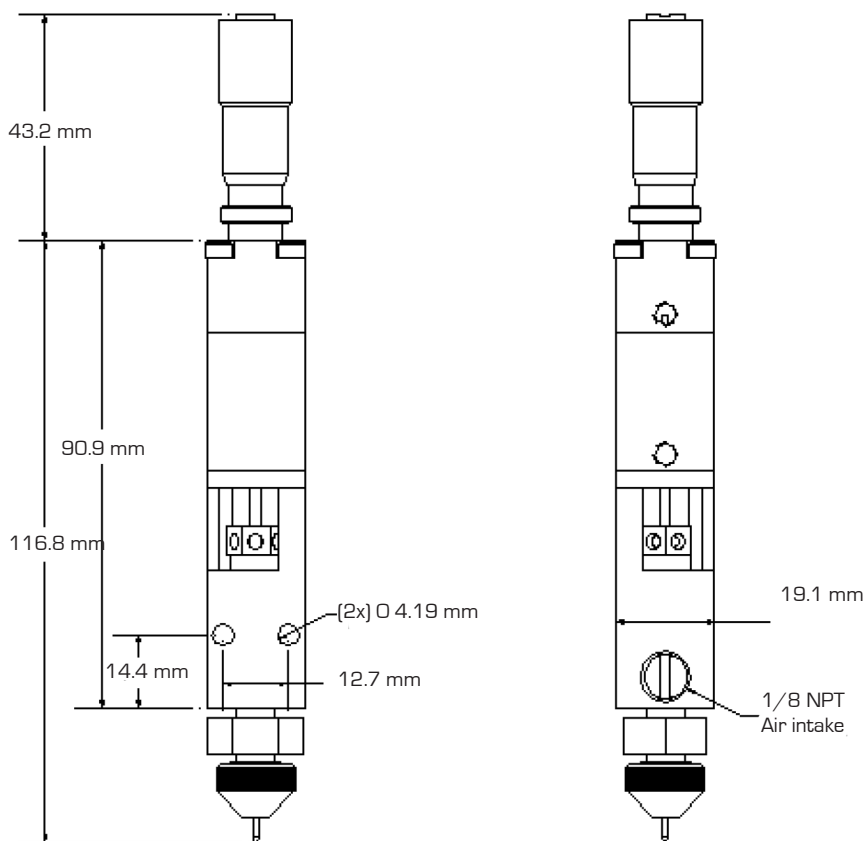

## Poly Dispensing Systems

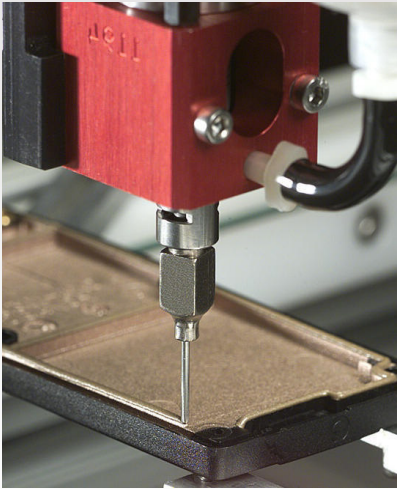

PDS S.A.S is a french company that commercializes a wide range of dosage equipments, proven and effective.

Distributed in over 20 countries around the world, these equipments provide tailored solutions to many users in order to improve technically their manufacturing and reduce their productions costs.

Our collaborators and sales engineers all have a strong technical competences. They are able to answer your questions and offer you, after analysis, the right solution for your particular need.

FRANCE - SWITZERLAND  
NORTH AFRICA  
Poly Dispensing Systems  
122, Chemin de la Cavée  
78630 Orgeval  
FRANCE

☎ + 33 (0)1 39 62 40 92

📠 + 33 (0)1 39 62 40 94

[www.polydispensing.com](http://www.polydispensing.com)

BELGIUM- NETHERLANDS  
LUXEMBOURG  
Gentec Benelux  
Rue de L'Industrie, 12  
B-1400 Nivelles  
BELGIQUE

☎ +32 2 351 1800

📠 +32 2 351 1962

[www.gentec-benelux.com](http://www.gentec-benelux.com)

- NON CONTRACTUAL DOCUMENT -

# POLY DISPENSING SYSTEMS

S Y S T E M E S   D E   D O S A G E   I N D U S T R I E L

122, Chemin de la Cavée - 78630 Orgeval • [contact@polydispensing.com](mailto:contact@polydispensing.com) • Tel : 01.39.62.40.92

[www.polydispensing.com](http://www.polydispensing.com)