



CA300
DIAPHRAGM VALVES

POLY DISPENSING SYSTEMS
S Y S T E M E S D E D O S A G E I N D U S T R I E L

Diaphragm Dispensing Valve

Advantages

- Delrin® fluid chamber
- Easy and fast calibration of the quantity
- High precision removal
- Small footprint acclaimed by the Vision Award
- Very low maintenance, only one moving part
- Patented Teflon® film coated silicone diaphragm
- Potential rate: greater than 600 cycles / minute
- No residual drop at the end of the cycle
- Double acting steering



Compatible products

Cyanoacrylates / Anaerobic
/ Adhesives / Activator
/ lubricants - oils / fluids
Epoxies / Solvents - Alcohols
/ liquid fats / Inks - Painting /
Electrolyte



The CA300 is a plastic dispensing valve suitable for applying cyanoacrylate adhesives and anaerobic chemistries.

The CA300 is a plastic dispensing valve suitable for applying cyanoacrylate adhesives and anaerobic chemistries. This versatile diaphragm dispense valve can be used for single component bead, dot, potting, or encapsulation projects.

The dual acting air cylinder and unique rigid diaphragm allow this valve to act as a front closing valve making it more desirable for accurate placement of small dots and fine bead patterns.

The lightweight and compact design makes it suitable for any automated, stationary, or handheld application. The CA300 has many integrated features including:

- Delrin® material body
- Adjustable flow control with locking set screw
- Divorced valve design prevents material contamination of the air section
- Spring assisted valve closure for reliable cycle stops
- Compatible with all Luer-Lok™ needle tip designs

Characteristics

Dimensions	128 mm x 29.21 mm x 29.21 mm
Weight	8 oz
Viscosity Range:	1 cps – Paste
Operating Air Pressure:	60 – 100 ps
Maximum Inlet Fluid Pressure:	100 psi
Wetted Components:	Teflon®, Delrin®, Polypropylene

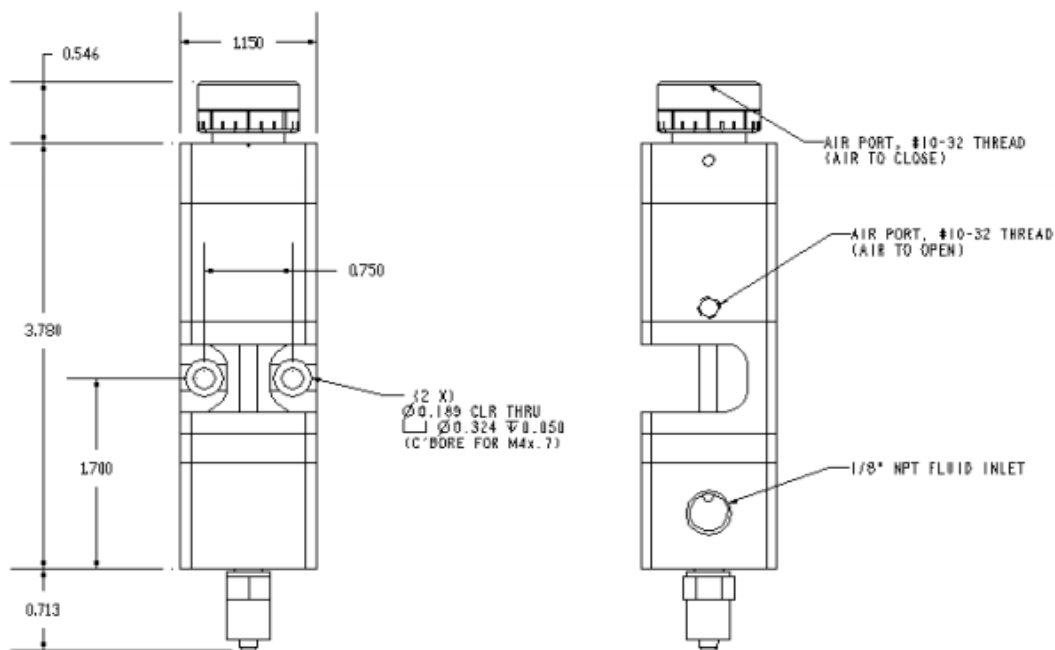

Poly Dispensing Systems



PDS S.A.S is a french company that commercializes a wide range of dosage equipments, proven and effective.

Distributed in over 20 countries around the world, these equipments provide tailored solutions to many users in order to improve technically their manufacturing and reduce their productions costs.

Our collaborators and sales engineers all have a strong technical competences. They are able to answer your questions and offer you, after analysis, the right solution for your particular need.

FRANCE - SWITZERLAND
NORTH AFRICA

Poly Dispensing Systems
122, Chemin de la Cavée
78630 Orgeval

FRANCE

☎ + 33 (0)1 39 62 40 92

📠 + 33 (0)1 39 62 40 94

www.polydispensing.com

BELGIUM- NETHERLANDS
LUXEMBOURG

Gentec Benelux
Rue de L'Industrie, 12
B-1400 Nivelles

BELGIQUE

☎ +32 2 351 1800

📠 +32 2 351 1962

www.gentec-benelux.com

- NON CONTRACTUAL DOCUMENT -

POLY DISPENSING SYSTEMS

S Y S T E M E S D E D O S A G E I N D U S T R I E L

122, Chemin de la Cavée - 78630 Orgeval • contact@polydispensing.com • Tel : 01.39.62.40.92

www.polydispensing.com